

## APPLICATION GUIDELINE #24

### (Application Considerations When Applying VFD's – PART 2)

Brought to you by your Motor & Drive Specialists.....

As mentioned in PART 1, when the speed of a LVM is to be controlled by a Variable Frequency Drive (VFD), there are a number of factors that must be considered. These factors include such things as: voltage, horsepower, line and load side harmonics, load torque and inertia, speed range, speed regulation and accuracy, acceleration/deceleration times, overspeed capability, braking requirements, power loss ride-through time, audible noise, length of cable from the VFD to the motor, enclosure requirements, area classification, power factor correction, altitude, efficiency, motor insulation life, and many other factors. Some of these factors are explained in more detail in the following paragraphs.

With respect to overspeeding motors, NEMA establishes certain parameters for maximum safe operating overspeed ranges. For the most part, smaller horsepower motors are to be designed to be capable of 200% overspeed and as horsepower increases the overspeed range decreases to as low as no overspeed capability required on 3600rpm( $\geq$ 60Hp) and 1800rpm( $\geq$ 350hp) motors and to 150% on 1200rpm motors right up to 350hp. Above base speed, the VFD & motor system operates in a constant HP mode. Torque at overspeed is reduced, linearly up to 150% overspeed and generally falls off as the square of the V/Hz ratio above 150% overspeed (See Application Guideline #10). At less than base (nameplate) speed, the VFD & motor system operates in a constant torque mode. Motor cooling is a function of motor speed, since the motor cooling fan speed is directly proportional to shaft speed. Therefore, at reduced speeds, motor cooling needs to be considered, and concern should be given both to stator temperature rise as well as drive end bearing temperature rise. A lack of cooling air from the motor's own fan can be compensated for by providing external cooling, independent of rotor speed, or by upsizing the motor.

Motor efficiency is reduced when controlled by a VFD, due to the harmonic content of the output wave form of the VFD, which results in harmonic heating of the motor stator and rotor. However, depending upon the degree of system voltage unbalance, the introduction of the VFD into the power circuit could result in a higher system efficiency, since the ASD outputs three perfectly balanced voltages to the motor.

A very important consideration in the application of VFD's on LVM is that of voltage stress on motor winding insulation. VFD's manufacture the AC output waveform from a DC source (which has usually been derived from the incoming AC power source). The inversion from DC to AC is generally accomplished by semiconductor switching devices, some of which may have very fast rise times (i.e.: high dV/dt). This high dV/dt stresses motor insulation, and is increased by large amounts of capacitance, such as from long cable lengths between the motor and the drive. It is important that the VFD manufacturer be aware of the consequences of voltage stress on motor insulation life, so that semiconductor rise times, carrier frequencies, cable lengths, filtering, etc. may all be considered in the design of VFD's and motors.

Carrier frequency is the rate at which the IGBTs fire to create PWM output. By increasing carrier frequency, thus creating more pulses per unit time, the resulting waveform better approximates a sinusoidal current waveform. The benefits of a high carrier frequency include less audible noise and less motor heating. Unfortunately, there are disadvantages with high carrier frequency regarding motor insulation stress and currents to ground. The PWM carrier frequency from most drive companies usually ranges from 2000 to 16,000 pulses per second (2-16 kHz). Standard

# TOSHIBA – DISTRIBUTOR NAME – PHONE (###) ###-### – TOSHIBA

induction motors were designed for a sine wave voltage. When an ASD puts DC pulses at high amplitude, more stress is placed on the windings. At short distances below fifty feet between the motor and ASD, there is considered to be little application concern. In the figure below, it shows the waveform on the drive output appears at the motor terminal unchanged with a typical peak of 813V.

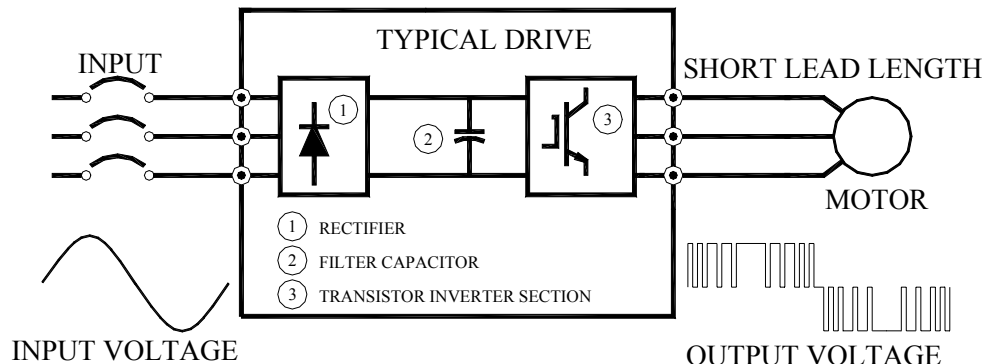

When motor lead length distances increase above 200 feet, the small values of inductance and capacitance that are insignificant to a sine wave can cause voltage ringing and even reflected waves that can raise peak voltages above 2000V. Higher carrier frequencies can add an additional stress by a doubling of voltage caused by reflected waves. Normal 813V peak levels can be as high as 2000 volts! Motor companies have responded to the insulation stress issues by improving motor insulation capabilities. NEMA MG-1-1998 Section IV Part 31 published a specification for motors used on drives that defines peak voltage and rise time [ $V_{peak} = 1.1 \times 2 \times (\sqrt{2}) \times V_{rated} = 3.1 \times V_{rated}$ , Rise time  $\geq 0.1 \mu s$ ]. There are also several methods of mitigating voltage stress using filters.

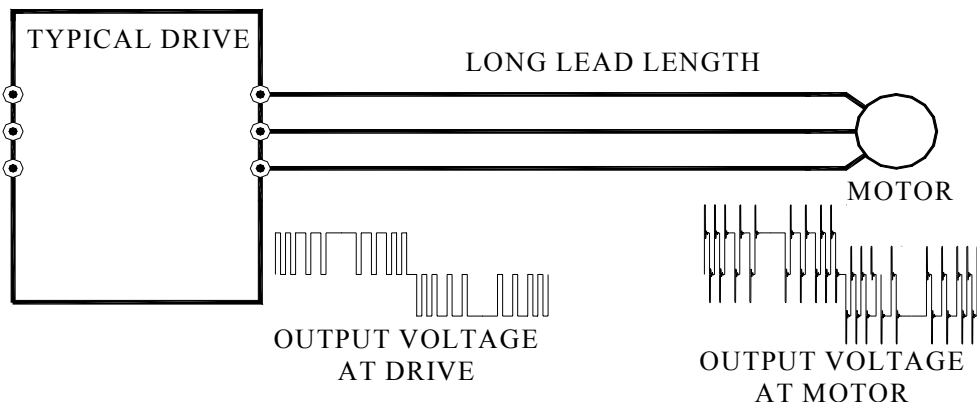

Toshiba EQP III motor designs meet the requirements specified in the 1998 guideline and there are simple guidelines for installing Toshiba motors on drives. Normal wiring methods may be used. No special cable is required except that motor leads be installed in separate conduit and not mixed with other wiring. The following lead length limitations are safe when used with a Toshiba EQP III motor and any Toshiba ASD.

<u>AC Motor Voltage</u>	<u>PWM Carrier Frequency</u>	<u>NEMA MG1-1998 Section IV Part 31 Compliant Motors</u>
230v	All	1000 ft.
460v	$\leq 5\text{KHz}$	600 ft.
460v	$\geq 5\text{KHz}$	300 ft.
575v	$\leq 5\text{KHz}$	200 ft.
575v	$\geq 5\text{KHz}$	100 ft

For distances greater than listed above, filters are available that can be mounted near the drive.

# TOSHIBA INTERNATIONAL CORPORATION

## Conclusions Regarding Insulation Stress

- Lower carrier frequencies are better for a motor insulation if audible noise is not a concern.
- Not all drives are the same. Check with each manufacturer for their recommendations. Some drives have higher voltage peak outputs and fast (shorter) rise time which both affect motor insulation negatively. Quality manufacturers will provide superior filtering around IGBT's.

'Motors suitable for use on VFD's' are motors that are specially designed to withstand the voltage stress of VFD output waveforms. Special measures include: changing motor windings from concentric to lap wind (to improve phase separation), increasing phase insulation thickness for higher dielectric strength, use of inverter duty magnet wire per MG1-Part 31 to improve dielectric withstand capability, multiple dipping and baking (or VPI treatment), increasing end winding bracing and sleeving of the first few turns of the windings to reduce the effects of dV/dt.

Some "inverter duty motors" from motor manufacturers are sold with a separately powered cooling fan for 1000:1 turn down ratios off the shelf, and in some cases may even have a specially designed rotor geometry which makes it unusable on across the line starts, however minimizes heating in the rotor due to PWM harmonics, and optimizes torque/amp ratios.

- It is Toshiba's recommendation, however, that if an application doesn't need an auxiliary blower, it should be avoided. (A blower adds one more level of complexity to an installation and can significantly add to the installation cost.) Further, the motors that we build for 1000:1 turndown ratio have exactly the same windings, rotor design, bearings, etc. as the standard EQPIII line of motors. The only difference is the addition of auxiliary equipment such as a blower and or an encoder.
- The NEMA MG1-1998, Part 31 specification states: Definite purpose "Inverter Duty" motors are not necessarily capable of across the line starting. If this is a requirement, this should be defined prior to ordering. For example, a motor specifically built for only ASD applications can have a huge amount of inrush current and very poor LRT. Many applications, however, incorporate bypass contactors or some other means of allowing the application to run across the line in the event of a drive failure. The Toshiba EQPIII series can handle both situations quite readily. Note that it is more expensive to manufacture a motor that provides optimum performance when operated on either sinewave or AC Adjustable Speed Drives, but that is what the industry in general prefers.

Motor audible noise is generally greater when controlled by a VFD. The noise is due to the motor laminations responding to the harmonic frequencies present in the ASD output waveform (much like the hum of a transformer vibrating to the 60 Hz input power frequency). This can be a concern when there is a possibility of resonance such as in ventilation ducts.

The use of VFD's on motors for use in classified areas requires special consideration. For instance, the presence of CSA label on a VFD and explosion proof motor does not necessarily mean that the combination of the VFD and the motor together is suitable for use in a hazardous Location (i.e.: a [Class I, Division 1](#) area, for example). The suitability of an explosion proof motor for a given area is, in part, a function of the skin temperature of the motor, which is determined by the application of a sinusoidal voltage. The output of a VFD contains some measure of harmonic content which results in increased motor heating, and higher skin temperature. This higher skin temperature may exceed the maximum temperature for the Group for which the motor is rated on a sinusoidal waveform. Some independent testing and certification agencies, such as Underwriters Laboratories (UL), have certified certain VFD & Motor combinations for use in hazardous locations. When specifying or purchasing a motor and VFD for classified areas, consult the manufacturer (preferably one which manufacturers both the motor and VFD) for help in sizing.

TOSHIBA - DISTRIBUTOR NAME - PHONE (###) ###-#### - TOSHIBA - DISTRIBUTOR NAME - PHONE (###) ###-####

TOSHIBA - DISTRIBUTOR NAME - PHONE (###) ###-#### - TOSHIBA - DISTRIBUTOR NAME - PHONE (###) ###-####

# Motor & Drive Specialists

TOSHIBA INTERNATIONAL CORPORATION